



Clean fuel is essential

Since water is potentially the most harmful contaminant in your fuel system, Baldwin Filters developed a line of heavy-duty fuel/water separators that are both rugged and reliable. Baldwin's fuel/water separators incorporate a heavy-duty, one-piece housing and other design features that eliminate the risk of failure associated with designs that use plastic bowls.

The DAHL®/Baldwin line of products provides additional protection to diesel fuel systems. DAHL fuel filter/water separators remove virtually 100% of the water and solid contaminants from your fuel system. The key to providing such efficient removal of contamination is DAHL's patented depressurizer cone and the design of the dual-chamber 3-stage fuel filter/water separator.

Clean fuel provided by a DAHL diesel fuel filter/water separator eliminates nearly all of the engine problems caused by water and solid contaminants in diesel fuel. In addition, you can expect:

- Longer Injection System Component Life
- Full Power Performance
- Lower Element Replacement Cost

Depend on Baldwin Filters

Protect your equipment with heavy-duty Baldwin filters. When it comes to coverage, Baldwin Filters provides the widest range of heavy-duty lube, air, fuel, coolant, hydraulic and transmission filters in the industry.

Baldwin consistently manufactures filters designed to meet or exceed the quality, performance and supply requirements of original equipment and aftermarket customers.

Africa
Baldwin Filters South Africa
 Ph: 27-21-534-0029
 Fax: 27-21-534-3730
 E-mail: africa@baldwinfilter.com

Australia & New Zealand
Baldwin Filters Aust., Pty. Ltd.
 Ph: 61-3-9353-7300
 Fax: 61-3-9353-7301
 E-mail: australia-newzealand@baldwinfilter.com

Central & South America
Baldwin Filters
 Ph: (308) 233-9220
 Fax: (308) 237-9769
 E-mail: latinamerica@baldwinfilter.com

China
CLARCOR Filtration (China) Co., Ltd.
 Ph: 86-0536-2606308
 Fax: 86-0536-8656108
 E-mail: china@baldwinfilter.com

Europe
Baldwin Filters N.V.
 Ph: 32 3 328 18 88
 Fax: 32 3 328 18 99
 E-mail: europe@baldwinfilter.com

Mexico
Filtros Baldwin de Mexico, S.A. de C.V.
 Ph: 52-442-227-3400
 Fax: 52-442-227-3427
 E-mail: mexico@baldwinfilter.com

Middle East
Baldwin Filters
 Ph: (308) 237-9782
 Fax: (308) 237-9769
 E-mail: middleeast@baldwinfilter.com

Morocco
Baldwin Filters
 Ph: (212) 22 70 00 25
 Fax: (212) 22 70 00 28
 E-mail: morocco@baldwinfilter.com

Russia
Baldwin Filters
 Ph: (308) 237-9749
 Fax: (308) 237-9769
 E-mail: russia@baldwinfilter.com

Southeast Asia & Pacific Rim
Baldwin Filters
 Ph: 65-6382-6619
 Fax: 65-6382-6182
 E-mail: southeastasia@baldwinfilter.com

UK & Ireland
Baldwin Filters Ltd.
 Ph: 44-1702-291668
 Fax: 44-1702-290846
 E-mail: uk-ireland@baldwinfilter.com



a CLARCOR company

Fuel System protection



BALDWIN FILTERS® BALDWIN

a CLARCOR company



4400 East Highway 30 • P.O. Box 6010
 Kearney, Nebraska 68848-6010
 Phone: (308) 234-1951 • Toll Free: (800) 822-5394
 Fax: (800) 828-4453 • Int'l Fax: (308) 237-9769
 Internet: www.baldwinfilter.com

Heavy-duty protection

Dirty fuel is a fact of life. Even with the development of cleaner-burning fuels, contaminants are still a major concern when it comes to fuel systems.

Baldwin fuel filters protect sensitive fuel system components, such as injection pumps and injectors, from damaging contaminants, which include:

- **Water** — destroys lubricative properties of your fuel, damaging fuel system components and resulting in fuel flow stoppage at cold temperatures.
- **Fungus and Bacteria** — plug fuel filters, feed on hydrocarbons and spread rapidly in the presence of moisture.
- **Precipitates (non-combustible materials)** — settle out of the fuel causing few problems.
- **Particulates (black, tar-like contaminants)** — plug fuel filters quickly.
- **Wax** — adds energy to diesel fuel; however, during cold weather, wax thickens and gels – slowing or stopping fuel flow.

Baldwin Filters offers more than 650 different fuel filters, coalescers and fuel/water separators to fit most applications.

Maximum performance

Baldwin Filters manufactures high quality fuel filters designed to perform according to the specifications established by engine and equipment manufacturers.

SAE J905 and ISO 19438 tests show Baldwin filters meet the minimum standards for contaminant removal efficiency and contaminant holding capacity. The following product comparisons illustrate Baldwin's performance.

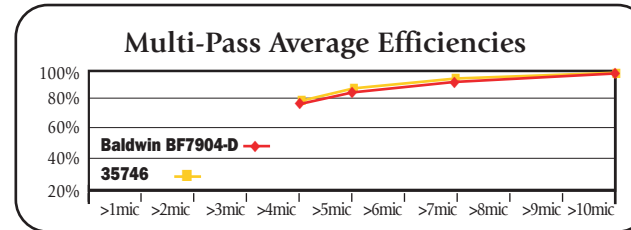
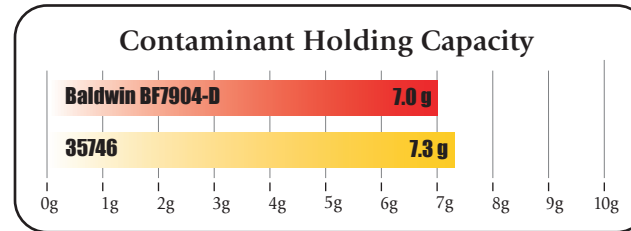

SAE J905 Test: Capacity: Flow Rate 2 gph, PFI Fine Test Dust, Dust Add Rate 2g/1g, Termination 5 psid. ISO 19438 Test: Efficiency: Flow Rate 0.8 gph, ISOMTD/5520M Test Dust, Termination 5 psid, Particle Size (microns)

Series II Fuel/Water Separators

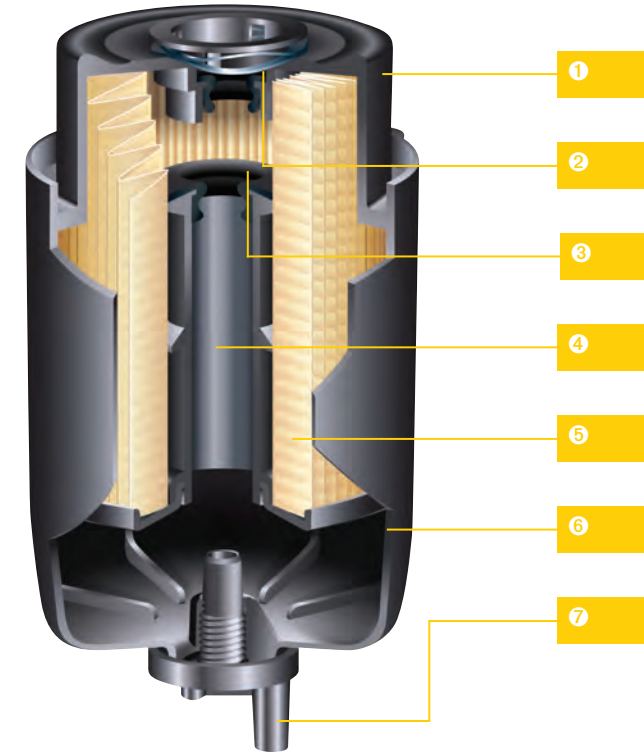

- ① **Raised Keys** eliminated for universal fit on multiple fuel bases.
- ② **Wave Spring** (Series II only) provides installation resistance for proper fit.
- ③ **Pliable Elastomeric Internal Seal** replaces hard plastic material, providing a positive sealing surface.
- ④ **Centertube** helps prevent collapse caused by a sudden difference between internal and external pressure.
- ⑤ **Highly Effective HydroShield™ Media** repels water and other contaminants, while assisting in the removal of water from the fuel.
- ⑥ **Heavy-Duty Housing** provides unequalled burst- and pulse-withstanding strength.
- ⑦ **Removable, Self-Venting Drain Valve** adds versatility for universal fit with OE bowls and sensors.

